



# Corporate Presentation

*January 2023*



*Experience the Power of Freedom*

## OUR MISSION STATEMENT

To produce engines so powerful, compact, and emission free that they become the preeminent choice for ground, sea, and air applications

## CORE VALUES

Quality

Continuous Improvement

Impact

Embrace the Future

Innovation

## Value Propositions

- State of the art R&D facilities to further enhance technology for Rotapower® engine
- To produce the most effective & efficient engines in the world, with crucial IP patented by FM or preserved as knowhow.
- Well documented, complete & detailed specifications for high volume production.
- All configurations of the engines have been developed, tested and deployed in applications.

## Executive Team

.....

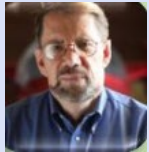

### Dr. Paul Moller - President

Dr. Paul Moller President. Founder of Moller International and Freedom Motors. Professor of Mechanical and Aeronautical Engineering at UC Davis 1963-75. Founder of SuperTrapp Industries, sold 1983. Masters in Engineering, PhD from McGill University. Received numerous patents.



### Dr. Subhash Paluru - CEO

Former Department of Energy Senior Executive, managed the Sierra Nevada Regional Office of Western Area Power Administration in Northern California. PhD from Osmania Univ.

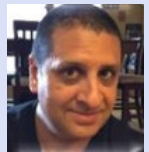

### David Sastry -COO

Former engineer with Intel Corporation, Freescale Semiconductor Inc, and Marvell Semiconductors Inc. Principal Consultant for Infosys IoT Practice. Masters in Engineering, Ohio State University.



### George Stevens - Chief Engineer

Former engineer of General Research Corp, and GSC Inc., expert in diesel engines. Program manager for development of Rotapower® engine and propulsion systems for the Moller Skycar, Volantors and Aerobots. BS in Electronic Engineering from BYU, BS in Mechanical Engineering from California State University.

## Board of Directors

.....



### Dr. Jim Toreson - Chairman

Expert in manufacturing, including quality control, materials management, JIT production, process control, and manufacturing engineering. BS, MS University of Michigan, Dr. of Science University of Nevada.



### Frank Verbeke

President and founder of Alturdyne, that designs and manufacturers engine systems using gas turbine, reciprocating, and rotary engines. BSME from the University of Michigan, Professional Engineer.



### John D'Alessandro

Former Principal Project and Process Systems Division Manager for SPEC Services, leading projects in wastewater, landfills, oil production, and power sectors.



### Kerry Bryant

President of Area P Inc., design, engineering, R&D, and manufacturing facility serving the motorcycle and automotive industry. Former Director of Sales and Marketing for SuperTrapp Industries.



### Dr. Shankar Yalamanchili, MD (Dr. Chili)

Dr. Chili is a Board Certified Psychiatrist, specializing in geriatric and adult psychiatry. Dr. Chili's primary practice is devoted to inpatient care and telepsychiatry services. As the owner of Alabama Psychiatry, Dr. Chili develops business interests for the company and strives to reach out to many providers of mental health services to positively impact wellness among this patient population.

## Board of Strategic Advisors

.....



### Sudheer Kuppam

Managing Partner of Epsilon Venture Partners, a Hong Kong based venture capital firm investing in APAC in technology sector. Before that he was the Vice President and Managing Director of Intel Capital for APAC region. Masters in Engineering, Rensselaer Polytechnic Institute



### Dr. Anjan Bose

Regents and Distinguished Professor in Electrical Power Engineering WSU Pullman. Former senior advisor to the secretary of US DOE on electric power grid in Obama administration. World renowned researcher in operation and control of power grid. BS, MS and PhD from IIT Kharagpur, UC Berkeley and Iowa State Univ. respectively.



### Dr. Gurminder Singh Khalsa

Gurminder Singh Khalsa is a scientist, technologist, entrepreneur, private and investment banker with 30+ years' experience. He Co-Chaired the International Green Technology Institute, an initiative of the Tom Bradley Legacy Foundation at UCLA, created various programs such as the Green Technology Leadership Lecture Series, the Green Technology Entrepreneurial Forum, the Green Technology Global Expo and Conference.



### Michael Shanley

Mr. Shanley has been a pilot since 1969, serving with the Royal Australian Air Force in Vietnam in 1971. He has been an enthusiastic supporter of Freedom Motors since its formation in 1997. Mr. Shanley holds a BA in English Literature from the University of Queensland, Australia and is the author of the novel, "Strela". Mr. Shanley is also Chairman of Shanley International Ltd., a company set up specifically to facilitate trade with China.



### Rajat Negi

Rajat is the CEO of No Carbon Energy Pvt Ltd, a green technology start-up based in Delhi, India. They have developed a unique Hybrid Waste-to-Energy plant with Carbon Capture & Sequestration to fight climate change. Sourcing energy from these hybrid plants is a near-perfect solution to two problems faced in the modern world: mounting waste and global warming. A thought leader for setting up an India operation for Freedom Motors international portfolio. Raising funds from Indian investors.

### *One child's dream to fly a car started it all....*

- At a young age of 15, designed a helicopter with materials from his father's farm
- 1957, Diploma from the Southern Alberta Institute of Technology to qualify as a certified airframe and powerplant technician
- 1963, M Eng. and a PhD in mechanical and aeronautical engineering from the McGill University
- Paul taught in the University of Davis where he created aeronautical engineering program and also constructed his first VTOL aircraft in his garage
- First VTOL aircraft **patented** in 1968, which later became known as **Neuera 200**
- In 1971, invented and patented the **Distributed Propulsion System** which is used even today by all VTOL aircraft manufacturers.
- Develop the 40-acre Davis Research Park and construct a 35,000 ft<sup>2</sup> manufacturing facility.
- Paul started **SuperTrapp** Industries and acquired **Kerker Exhaust Systems** and later sold to raise funds for engine development. SuperTrapp Industries still exists as a multibillion-dollar company.
- Paul also undertook several government funded contracts that resulted in various projects for unmanned aerial vehicles (UAV) for the US Army, Navy, and Air Force.

**To meet its performance goals the Neuera 200 needed an engine with a power to weight ratio substantially higher than any available!**

**\$65 million was specifically used for advanced development of Rotapower® engines**



**Dr. Paul Moller**

## ***Freedom Motors engine development journey.....***

- **General Motors Corporation (GMC) Rotary Engine Assets**

GMC had spent over \$500 million on R&D and tooling to produce their proprietary rotary engine. GMC's equipment & tooling specific to rotary engine production which was supplied by Gleason Machine Works was acquired by FM in 1988.

- **Outboard Marine Corporation (OMC) Rotary Engine Assets**

OMC had spent about \$250 million developing rotary engines for their snowmobile and the outboard motor markets. OMC was the largest manufacturer of outboard motors in the world was acquired by Bombardier (Canada). As part of the acquisition FM acquired the complete production manufacturing details and rotary engine inventory held by OMC in 1985. FM is now the only supplier of rotary engine parts for the OMC snowmobiles.

- **Infinite Engine Company (IEC)**

IEC, a listed company gave FM a \$2 million contract to develop a rotary engine for an unmanned aerial vehicle (UAV) for its client General Electric Aerospace. As part of IEC's internal restructuring FM took over IEC's production equipment & tooling.

## ***Significant developments began after acquisitions.....***

- FM and its technology partner, Moller International, together hold 12 engine related mechanical patents, 5 design patents and other technological patents totaling 49. Eight more patents are ready to be submitted.

***FM's continuous and focused development along with extensive additional research and testing resulted in the Rotapower® engine technology.***



“Paul Moller and Freedom Motors have been leaders in the development of the modern rotary engine since 1985” – Dr. Andrew Berke

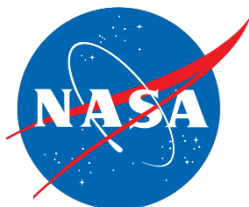

“Advantages derived are higher specific power, longer life, and lighter structure.” – NASA Lewis Research



“Incorporating NASA technology into the Rotapower® engine gives it the ability to run cleanly and efficiently on a variety of fuels.” – NASA STI



## Introducing Rotapower®

### 1 Powerful

- Achieves a power-to-weight ratio that is three times higher than its nearest competitor. Its power-to-volume ratio is five times higher

### 2 Few Moving Parts

- Only two moving parts in a single rotor engine.
- Compares to five parts for 2-stroke and 16 parts in a 3-cylinder, 4-stroke piston engine, with equivalent instantaneous output of torque.

### 3 Modular Design

- Stacking of rotors easily extends range of available power.

### 4 Low Vibration Levels

- Perfect radial balance allows rigid mounting which can become part of the structure.

### 5 Long Life

- Wear surface and seal life documented at over 20,000 hours.

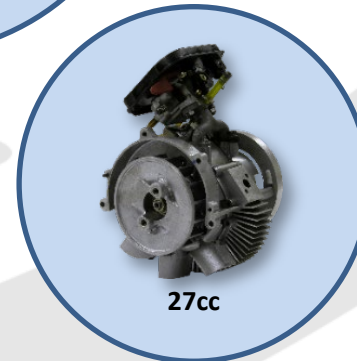
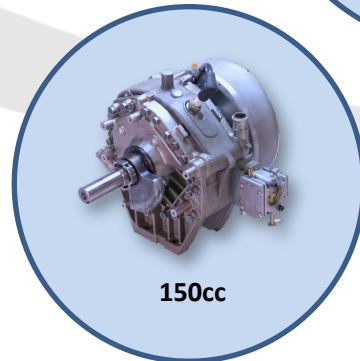
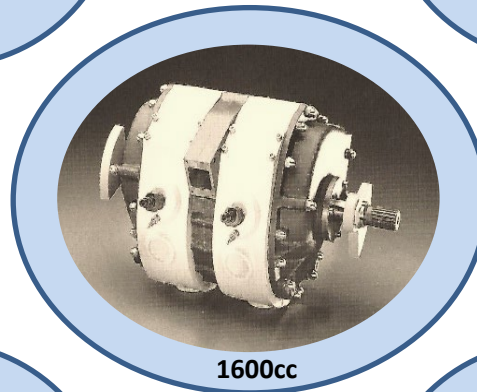
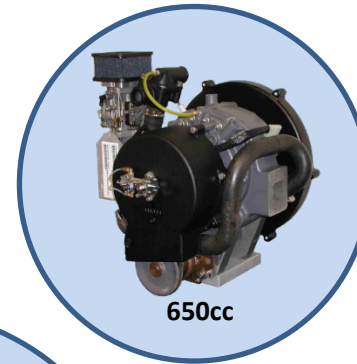
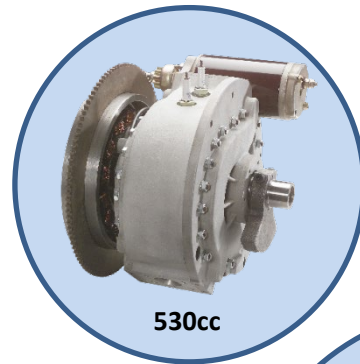

### 6 Very Low Toxic Emissions

- Less than 9% of the toxic emissions produced by industrial or commercial 4-stroke piston engines operating on gasoline.
- On alcohol, the emissions were independently documented at less than 0.2%.

### 7 Low Fuel Consumption

- Thermal efficiency is 32%, which exceeds most industrial or commercial engines.
- Compound version predicts 40% efficiency based on NASA-related test results.

### 8 Multi-Fuel Capable

- Demonstrated on gasoline, natural gas, alcohol propane, diesel and kerosene.

### 9 Quiet

- Compound version reduces noise by 27 dba (95%)

## Standard Engine

Four-Cylinder, 4-Stroke  
Piston Engine

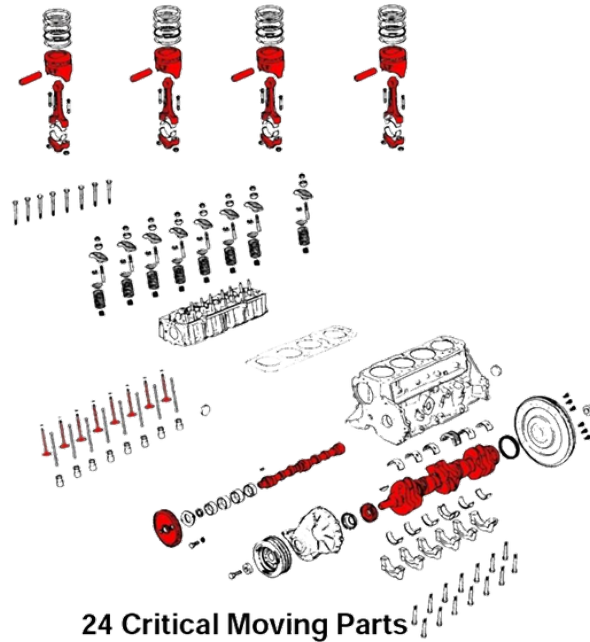

24 Critical Moving Parts  
32 Total Moving Parts

## Rotapower<sup>®</sup>

One-Rotor, 4-Stroke  
Rotapower<sup>®</sup> Rotary Engine

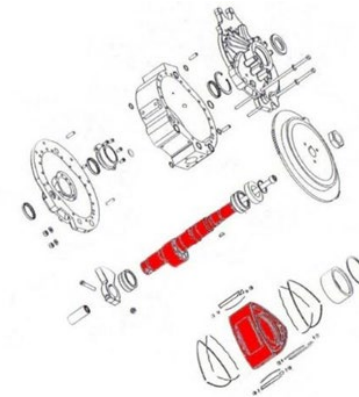

2 Critical Moving Parts



## Helping Clean the Planet

Rotapower® engines have the unique ability to efficiently consume contaminated methane. Methane is up to 85 times worse than CO<sub>2</sub> per molecule at retaining atmospheric heat\*\*. In the attached chart virtually all the sources of methane emissions are contaminated by H<sub>2</sub>S and/or silica except a portion of natural gas.

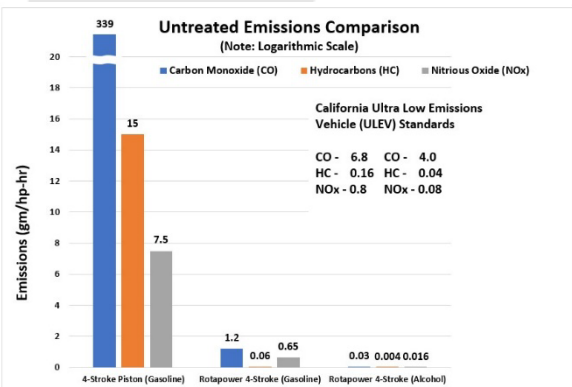
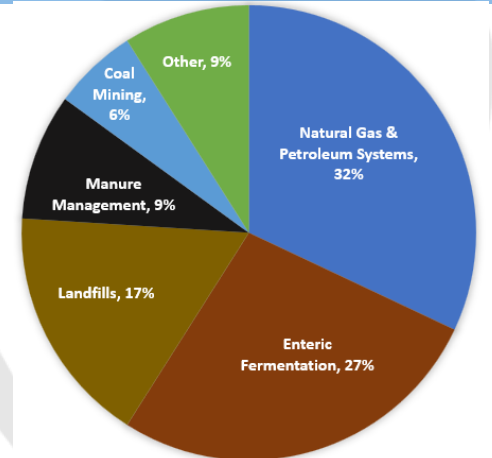

## Providing Emissions Free Power

Rotapower® engines are designed to operate on emission free fuels like hydrogen or carbon neutral fuels like renewable methanol where toxic emissions, if they exist, are so low that they are difficult to measure. This includes nitrous oxides which retain up to 900 times more heat than CO<sub>2</sub> per molecule and are considered a serious health risk.

Piston engine data from EPA report No. NR-0106  
Rotapower engine data verified by California Air Resource Board (CARB) and Dr. Andrew Burke of the Institute of Transportation Studies (ITS), University of California, Davis

## Powering Personal Airborne Mobility

Rotapower® engines have a power-to-weight ratio that is three times higher than today's best aircraft engine. Consequently, it is the only viable candidate to power the Advanced Air Mobility aircraft market that Morgan Stanley predicts will exceed \$9 trillion by 2050.



\*\* "Surge in methane emissions threatens efforts to slow climate change"; phys.org, 12 Dec 2016; <https://phys.org/news/2016-12-surge-methane-emissions-threatens-efforts.html>. Accessed 1 November 2017.

**Notable Features Comparison of Various Engines**

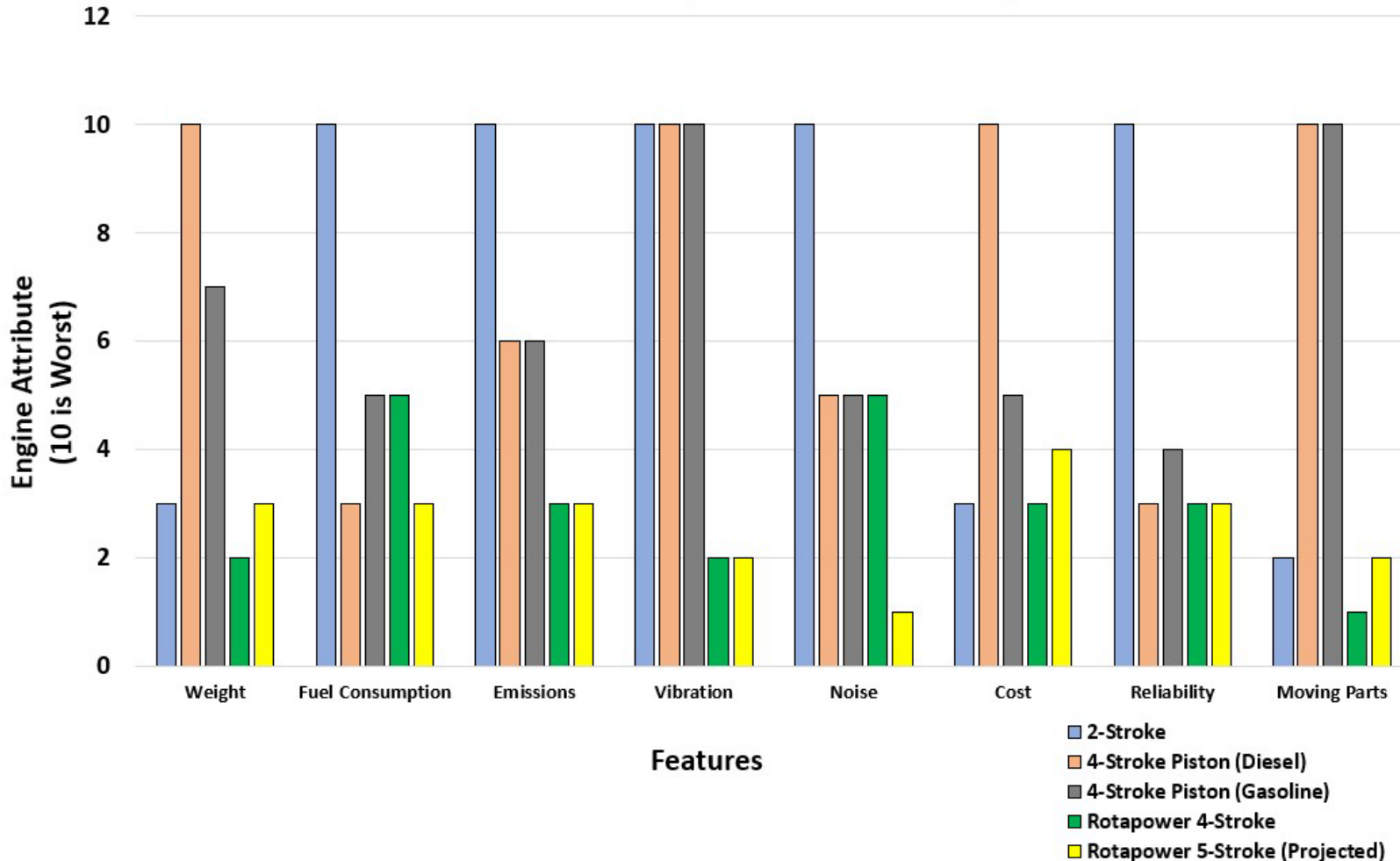

- Tests carried out in conjunction with the Institute of Transportation Studies (ITS) at the University of California at Davis as witnessed by members of the California Air Resources Board (CARB).
- The Rotapower® engine using gasoline as a fuel achieved hydrocarbon, carbon monoxide, and nitrous oxide emission levels well below those required to meet the Ultra-Low Emission Vehicle (ULEV) standards for California. Using methanol resulted in emissions well below the Super Ultra Low Emission Vehicle (SULEV) California standards
- This was accomplished without exhaust after-treatment (catalytic converter) which had not been previously achieved with any other engine technology.



Model	Marine	Rotapower® 1060
Power (hp)	250	250*(175 Compound)

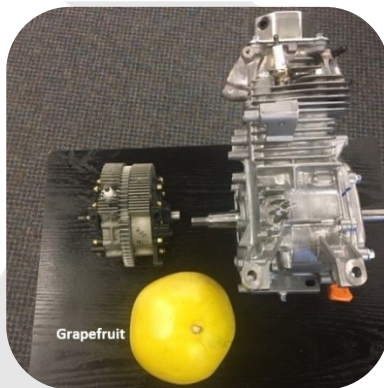

Model	Scooter	Rotapower® 54
Power (hp)	6.5	12(7.6 Compound)

\*With alcohol fuel

Attributes	Non Automotive Piston Engine	Freedom Rotapower® Engine Simple/Compound
Power to weight ratio	0.94	3.33/2.69
Power to volume ratio	56	312/269
Critical moving parts	52 (six cylinder)	2/3
NO <sub>2</sub> emissions (gasoline)**	7.5 gm/hp-hr	0.65 gm/hp-hr
CO emissions (gasoline)**	338 gm/hp-hr	1.2 gm/hp-hr
Hydrocarbon emissions (gasoline)**	15 gm/hp-hr	0.06 gm/hp-hr
Thermal efficiency	30%	32%/40%
Engine Life	1,500-2,000 hrs.	20,000 hrs.
Vibration	Substantial	Negligible
Muffled noise at 25 feet	93 dba	87 dba/ 66 dba
Weight	265 lbs.	75/105 lbs.
Volume	4.5 cubic feet	0.5/0.8 cubic feet
Equivalent displacement	2600cc	1060cc
Multi-fuel Capable	No	Yes

\*\* Emissions with alcohol fuel are significantly lower and almost negligible (undetected)

- Oil-cooled rotor rotary engines:
  - Mazda (Automotive only)
  - NSU (Automotive only)
  - Ingersoll-Rand (Industrial only)
- Charge-cooled rotary engines:
  - Infinite Engine Company (acquired by FM)
  - Fichtel-Sachs (not actively manufacturing rotary engines)
  - Norton (primarily in motorcycle space)
  - OMC (acquired by FM)
  - Freedom Motors (VTOL Aircraft, EVs, Automotive, Outboard, Generators, Power tools, etc...)

## ONEH2 GENSET

- Zero emissions on **hydrogen**
- Occupies less than one cubic foot volume
- Generates very low noise
- Essentially vibration free
- Low cost & maintenance

- **Materials Handling Equipment**
- **Forklifts**
- **Trucks**
- **Stationary Generators**
- **EV Charging Stations**



## 2 & 3-WHEELER

- Occupies less than half cubic foot volume
- Runs on any fuel type
- Very low toxic emissions on gasoline
- Near zero toxic emissions on alcohol
- Generates very low noise
- Essentially vibration free
- Carbon neutral on renewable methanol
- Low cost & maintenance

- **2 Wheelers**
- **3 Wheelers**
- **Motorized Bicycles**
- **Main Powerhouse or**
- **Hybrid Configuration**



## POWER TOOLS

- Runs on any fuel type
- Very low toxic emissions on gasoline
- Near zero toxic emissions on alcohol
- Generates very low noise
- Essentially vibration free
- Carbon neutral on renewable methanol
- Low cost & maintenance

- **Agriculture**
- **Construction**
- **Lawn & Garden**
- **Industrial**



## BIOGAS Consumer

Tolerates wastewater and landfill silica contaminants using near diamond-hard wear surfaces and lack of valves  
Resists hydrogen sulfite contaminants of the lubrication system using a metered oiling system  
Can operate on biogas with low methane content



**Biogas Test Dyno**

## RECREATION

- High power-to-weight ratio
- High power-to-volume ratio
- Essentially vibration-free
- Low noise
- Very low emissions
- Low cost & maintenance



## EV RANGE EXTENDER

- Occupies less than one cubic foot volume
- Runs on any fuel type
- Very low toxic emissions on gasoline
- Near zero toxic emissions on alcohol
- Generates very low noise
- Essentially vibration free
- Carbon neutral on renewable methanol

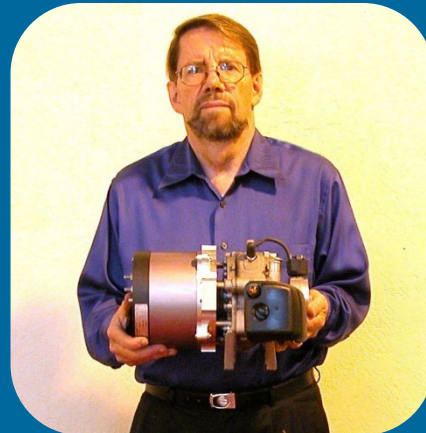

**15 Kw of gasoline  
30 Kw on alcohol**

## GENERATORS

- Excellent system for dispatchability
- High power to weight ratio
- Runs on any fuel
- Carbon-neutral on renewable methanol
- Extremely low toxic emissions
- Power options start from 2Kw up to 500 Kw



Rotapower® genset

Variable frequency  
Variable voltage  
75 lbs. weight  
Volume 2 cubic feet  
Output on gasoline 15 Kw  
Output in alcohol 30 Kw

Gen-Pro genset

Fixed frequency  
Fixed voltage  
425 lbs. weight  
Volume 8 cubic feet  
Output 13.5 Kw

## MARINE

- High power-to-weight ratio
- High power-to-volume ratio
- Essentially vibration-free
- Low noise
- Very low emissions
- Low cost & maintenance
- **Patrolling Boats**
- **Small & Medium size ferry boats**
- **Fishing boats**
- **Small & Medium size Freight Boats**



## AAM VTOL

### Skycar® Volantors

- Runs on gasoline, ethanol and methanol
  - 1-4 occupants
  - Cruising speed 235 mph
  - Range 450 miles
  - Fits in a single car garage
  - Can land at the curb near one's home or business
- **Air taxi service**
  - **Private use**
  - **Border patrol**
  - **Paramilitary**



## Unmanned AAM VTOL

### Aerobots

- Electric or fuel powered
  - Run on any fuel
  - Scalable range and payload
  - Adjustable speed- remotely and autonomously
  - Low cost & maintenance
- **Agriculture**
  - **Construction**
  - **Inspection and**
  - **Damage Assessment**
  - **Package Delivery**
  - **Physical Security**



## Utility AAM VTOL

### Firefly

- Runs on gasoline, ethanol and methanol
  - 1-4 occupants including pilot
  - Cruising speed 75 mph
  - Maximum range of 80 miles
  - Low investment and maintenance cost
  - Low noise and emissions
- **Agriculture**
  - **Construction**
  - **Search and Rescue**
  - **Inspection and Damage Assessment**
  - **Physical Security**



**Annual Global Engine Production in 2016: 100%= 250 million units  
(Million units by Segments)**

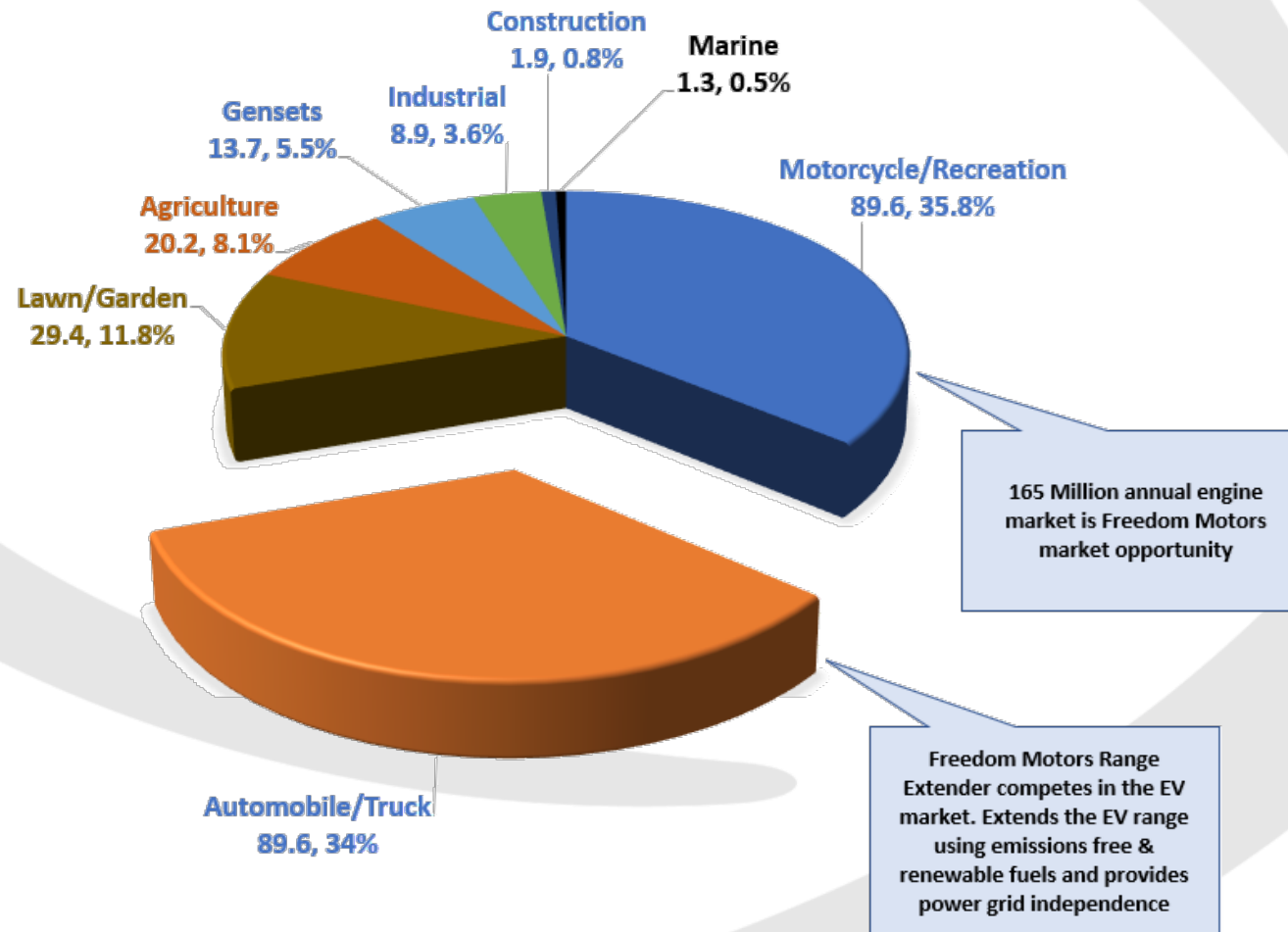



FM, using its previous acquisitions of Outboard Marine Corporation (OMC) and majority of the General Motors Corporation (GMC) rotary engine division, as the basis and foundation, further developed the engine technology and made it commercially viable. Freedom Motors and its technology partner, Moller International, together hold 12 engine related mechanical patents, 5 design patents in total and many other technological patents making up to 49 in total. FM has many trade secrets and 8 patents in process or ready to be processed.

The patents concerning aircraft are also included in this list. The success of Moller aircraft is only possible with the Freedom Motors engines, and therefore, it is important to understand that these patents are related to each other for the overall success of the project. [The full potential of our patents are only realized when combined with our trade secrets.](#)

#### TOP 10 Patents...

- 1). Patent D736,140  
"Vertical takeoff and landing vehicle" - Aug 11, 2015
- 2). Patent D498,201  
"Vertical takeoff and landing aircraft" - Nov 4, 2004
- 3). Patent 6,808,140  
"Vertical take-off and landing vehicles" - Oct 26, 2004
- 4). Patent 6,450,445  
"Stabilizing control apparatus for robotic or remotely controlled flying platform" - Sept 17, 2002
- 5). Patent 6,325,603  
"Charge cooled rotary engine" - Dec 4, 2001
- 6). Patent 6,164,942  
"Rotary engine having enhanced charge cooling and lubrication" - Dec 26, 2000
- 7). Patent 5,413,877  
"Combination thermal barrier and wear coating for internal combustion engines" - May 9, 1995
- 8). Patent 5,115,996  
"VTOL aircraft" - May 26, 1992
- 9). Patent D312,068  
"Vertical take-off and landing aircraft" - Nov 13, 1990
- 10). Patent 4,795,111  
"Robotic or remotely controlled flying platform" - Jan 3, 1989

Freedom Motors (FM) did not file for any new patents in the last few years. It was strategically planned to address

- a). The research and development of additional ways to extend the engine life, improve fuel efficiency, and increase power output, which has led to several additional claims to be patented.
- b). The mass manufacturing that was planned to occur only after significant and satisfactory improvements in critical areas like fuel efficiency and power output.
- c). The US and worldwide patents which takes significant time, funds, and human resources. FM planned to raise funds for manufacturing and patenting at the same time.
- d). FM technology that has resulted in several patents and can be said with complete confidence based on Dr. Moller's experience where over the years he has applied for and received over 15 patents, and never had a patent application rejected.
- e). The previous patents to ensure they are usually combined with our trade secrets, so it becomes extremely hard to replicate by third parties, to realize the full potential in rotary engines.
- f). FM's numerous trade secrets without patenting as they are very sensitive and can't be reverse engineered. For example, FM uses a mixture of Shell Rotella oil and other materials for metered lubrication (patented technology). The oil mixture that goes into the engine during expansion and compression cycles has a secret recipe that will be kept as trade secret. Similarly, there are many other trade secrets.

#### Proposed Patents

- 1). A specific combination of engine displacement, engine RPM and brake mean effective pressure (BMEP) that allows the Rotapower® engine to operate on the Otto cycle while using diesel fuel.
- 2). A much improved fuel/air charge pathway through the rotor developed to improve cooling of the rotor and vaporization of the charge.
- 3). The new design further improved rotor cooling enough to allow the Rotapower® engine to produce two and one half times as much power for the same displacement as the OMC engine (102 hp from 530cc).
- 4). A compound version of the rotary engine where two rotors are able to function in series rather than parallel.
- 5). Unique one-way valve. The compound rotary engine requires a means to allow the charge to flow in one direction while not allowing it to flow in the reverse direction.
- 6). A rotor cooling arrangement employing a phase change of a liquid that allows almost unlimited cooling of the rotor.
- 7). a seal and rotor housing coating material combination that along with a proprietary rotor housing wear surface finish, allowed the wear surface and seal life to exceed a documented 20,000 hours versus 400 hours in the original OMC engine.
- 8). A mechanical patent specifically addressing the UAV (Unmanned Aerial Vehicle) design of Stella-1000 with Freedom Motors engines (**Patent Pending**)

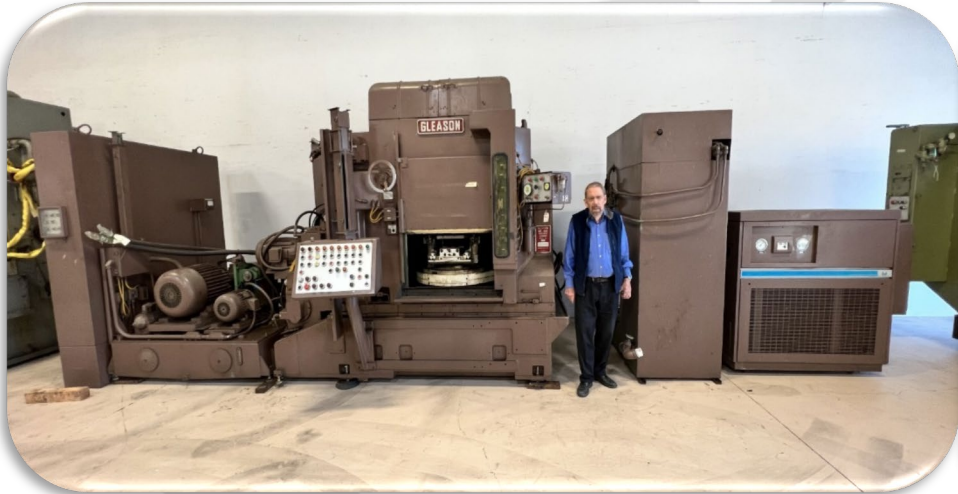

**Gleason Rotor Housing Grinder**



**Rotor Housing Honing Machine**



**Surface Grinder**



**Gleason Side-seal Slotter  
(We own two machines)**



**3-axis Machining Centers**

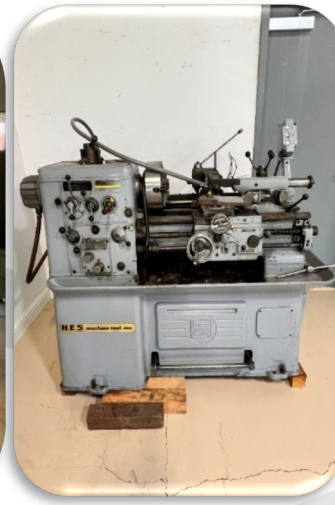

**Tracer Lathe**



**Manual Side-seal Slotter**

- Freedom Motors has:
  - 5,000 Sq. Ft of leased space for office and R&D activities
  - 8,000 Sq. Ft. of leased space for manufacturing
  - 5,000 Sq. Ft. newly constructed space for engine testing, storage and dyno facility
- In addition to the equipment shown in the images, Freedom Motors is also in the process of acquiring more state-of-the-art equipment such as 4-axis CNC, automated lathe, fully automated testing and Q&A equipment.
- The Gleason equipment shown in the images (Automated rotor housing grinder and side-seal slotter machine) are part of the General Motors contract worth \$150 million to Gleason Engineering for developing state-of-the-art mass manufacturing equipment specifically for rotary engines. After development, Gleason Engineering built a few of these machines.
- The current cost of the Gleason rotor housing grinder is approximately \$4 million and that of Gleason side-seal slotter is \$2 million. **The total replacement cost of all the equipment is approximately \$8-9 million.**
- The Gleason side-seal slotter can slot each rotor (6 slots) in 1 minute, whereas the best automated equipment today can take 30 minutes.

Q&A

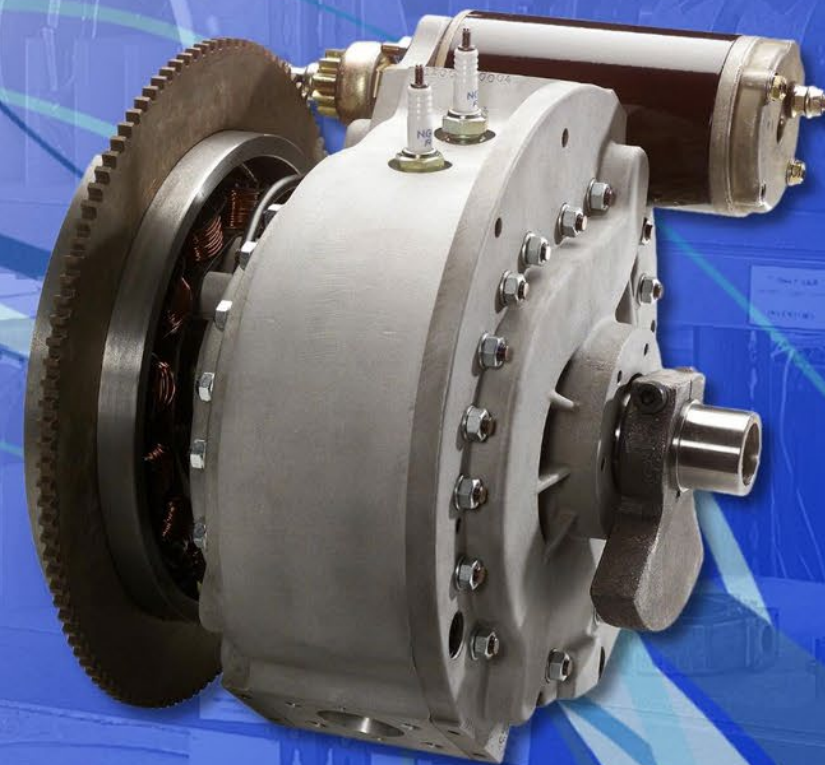

Corporate HQ  
410 Gateway Plaza, Suite G  
Dixon CA 95620  
[www.Rotapower.Energy](http://www.Rotapower.Energy)

*Experience the Power of Freedom*